

TS7329K - 100W Asymmetric Peak Power GaN Broadband SPDT Switch

1.0 Features

- Low insertion loss (TX/RX): 0.4/0.6dB @ 2600MHz
- High isolation (RX Path): 40dB @ 2600MHz
- High peak power handling capability
- No external DC blocking capacitors on RF lines
- All RF ports OFF state
- Versatile 2.6-5.5V power supply
- Operating frequency: 500MHz to 5GHz

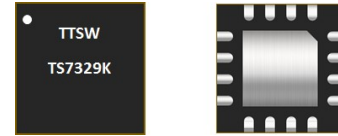

Figure 1 Device Image
(16 Pin 3×3×0.8mm QFN Package)

2.0 Applications

- 4G, 5G systems
- RX protection
- Cellular infrastructure
- Small cells
- LTE relays and microcells
- Radar



RoHS/REACH/Halogen Free Compliance

3.0 Description

The TS7329K is an asymmetrical reflective Single Pole Dual Throw (SPDT) switch designed for broadband, high peak power switching applications. Its broadband behavior from 500MHz to 5GHz frequencies makes the TS7329K an excellent switch for all applications requiring low insertion loss, high isolation and high linearity within a small package size.

The TS7329K is packaged into a compact Quad Flat No lead (QFN) 3x3mm 16 leads plastic package.

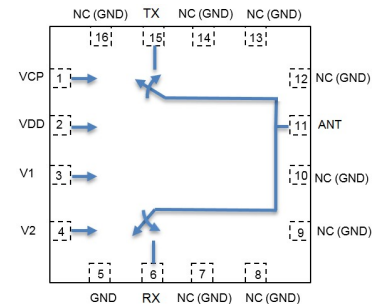

Figure 2 Function Block Diagram
(Top View)

4.0 Ordering Information

Table 1 Ordering Information

Base Part Number	Package Type	Form	Qty	Reel Diameter	Reel Width	Orderable Part Number
TS7329K	16 Pin 3×3×0.8mm QFN	Tape and Reel	3000	13" (330mm)	18mm	TS7329KMTRPBF
Evaluation Board						TS7329K-EVB

5.0 Pin Description

Table 2 Pin Definition

Pin Number	Pin Name	Description
1	VCP	Internal charge pump voltage output. Connect a 1nF capacitor to GND on this pin to improve switching time.
2	VDD	DC power supply
3	V1	Switch control input 1
4	V2	Switch control input 2
6	RX	RX port
5,7,8,9,10,12,13,14,16	NC	No internal connection, Can be grounded
11	ANT	Antenna port
15	TX	TX port

Note: The backside ground (thermal) pad of the package must be grounded directly to the ground plane of PCB with multiple vias to ensure proper operation and thermal management.

6.0 Absolute Maximum Ratings

Table 3 Absolute Maximum Ratings @ $T_A=+25^{\circ}\text{C}$ Unless Otherwise Specified

Parameter	Symbol	Value	Unit
Electrical Ratings			
Power Supply Voltage	VDD	2.6 to 5.5	V
Storage Temperature Range	T_{st}	-55 to +125	$^{\circ}\text{C}$
Operating Temperature Range	T_{op}	-40 to +85	$^{\circ}\text{C}$
Maximum Junction Temperature	T_J	+140	$^{\circ}\text{C}$
RF Input Power CW, 800MHz, $T_J=+85^{\circ}\text{C}$	TX-ANT	42	dBm
RF Input Power CW, 800MHz, $T_J=+105^{\circ}\text{C}$	TX-ANT	41	dBm
Thermal Ratings			
Thermal Resistance (junction-to-case) – Bottom side	$R_{\theta JC}$	25	$^{\circ}\text{C}/\text{W}$
Thermal Resistance (junction-to-top)	$R_{\theta JT}$	36	$^{\circ}\text{C}/\text{W}$
Soldering Temperature	T_{SOLD}	260	$^{\circ}\text{C}$
ESD Ratings			
Human Body Model (HBM)	Level 1B	500 to <1000	V
Charged Device Model (CDM)	Level C3	≥ 1000	V
Moisture Rating			
Moisture Sensitivity Level	MSL	1	-

Attention:

Maximum ratings are absolute ratings. Exposure to absolute maximum rating conditions for extended periods may affect device reliability. Exceeding one or a combination of the absolute maximum ratings may cause permanent and irreversible damage to the device and/or to surrounding circuit.

7.0 Electrical Specifications

Table 4 Electrical Specifications @ $T_A=+25^{\circ}\text{C}$ Unless Otherwise Specified; $V_{DD}=+3.3\text{V}$; 50Ω Source/Load.

Parameter	Condition	Minimum	Typical	Maximum	Unit
Operating Frequency		500		5000	MHz
Insertion Loss, TX	800MHz		0.30	0.40	dB
	1.95GHz		0.35	0.45	
	2.6GHz		0.40	0.55	
	3.8GHz		0.40		
	5.0GHz (with match. See page 4)		0.45		
Insertion Loss, RX	800MHz		0.50	0.65	dB
	1.95GHz		0.55	0.70	
	2.6GHz		0.60	0.75	
	3.8GHz		0.70		
	5.0GHz (with match. See page 4)		0.85		
Isolation ANT-TX	800MHz	39	42		dB
	1.95GHz	30	33		
	2.6GHz	27	30		
	3.8GHz		27		
	5.0GHz (with match. See page 4)		23		
Isolation ANT-RX	800MHz	52	55		dB
	1.95GHz	42	45		
	2.6GHz	37	40		
	3.8GHz		35		
	5.0GHz (with match. See page 4)		30		
Return Loss ANT-TX, RX	800MHz		30		dB
	1.95GHz		25		
	2.6GHz		23		
	3.8GHz		22		
	5.0GHz (with match)		18		
Isolation @ Peak Power	Peak power=49.2dBm, Isolation RX @3.8GHz		35		dB
Harmonic distortion					
H2	800MHz, Pin=35dBm		-40		dBm
H3	800MHz, Pin=35dBm		-45		dBm
IIP3	800MHz		70		dBm
P0.1dB ^[1] TX	700MHz~3.8GHz, CW	42			dBm
Peak P0.1dB TX ^[2]	700MHz~3.8GHz, pulsed power	49.2	50		dBm
P0.1dB ^[1] RX	700MHz~3.8GHz, CW	39			dBm
Switching Time	50% ctrl to 10/90% of the RF value is settled. C1=1nF (refer to Figure 3)		0.35		μs
Control Voltage	Power supply VDD	2.6	3.3	5.5	V
	All control pins high, V_{ih}	1.0	3.3	5.25	V
	All control pins low, V_{il}	-0.3		0.5	V
Control Current	All control pins low, I_{il}		0		μA
	All control pins high, I_{ih}			7.5	μA
Current Consumption, IDD	Active mode		160	200	μA

Note:

[1] P0.1dB is a figure of merit.

[2] 1% duty cycle and 10 μs pulse width.

[3] No external DC blocking capacitors required on RF pins unless DC voltage is applied on a RF pin.

8.0 Switch Truth Table

Table 5 Switch Truth Table

V1	V2	Active RF Path
0	1	All OFF
0	0	ANT-TX
1	0	ANT-RX

Attention:

- [1] VDD should be applied first before V1 and V2, otherwise may cause damage to the device.
- [2] There are internal pull-downs to ground on both V1 and V2 control pins, the state at start-up without any control voltage applied will be ANT-TX ON.
- [3] If all OFF state is not used, the switch can be operated with single control pin V1.

9.0 Evaluation Board

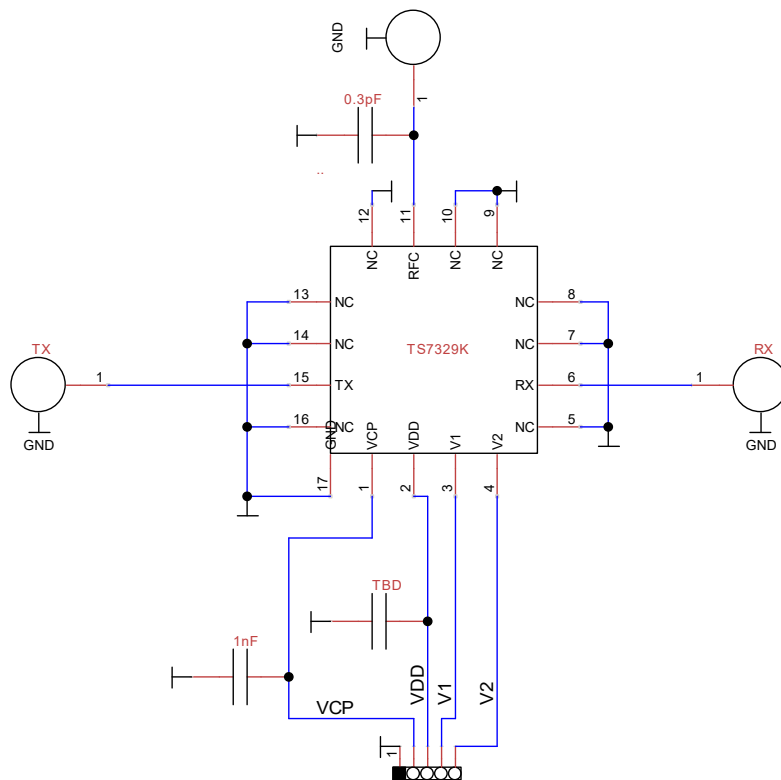

Figure 3 Evaluation Board Schematic

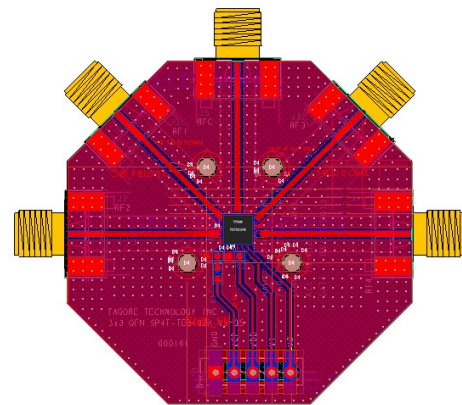

Figure 4 Evaluation Board Image

Attention:

- [1] 17 refers to the center pad of the device.
- [2] The purpose of connection between VCP and connector N1 is to monitor VCP, do not apply external voltage to VCP.
- [3] Below 4GHz, no match required on ANT port.
- [4] For 4.4~5GHz : Add 0.3pF (Passive Plus 0402N0R3AW251) to GND close to RFC pin.

10.0 Typical Characteristics
10.1 With No Match

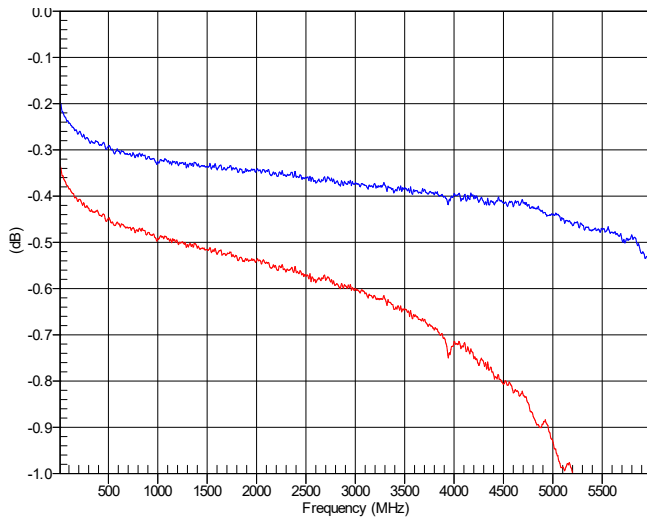

Figure 5 TX, RX Insertion Loss

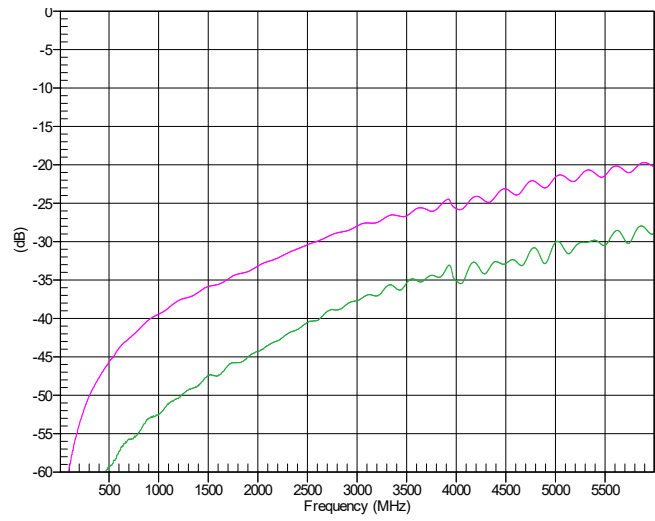

Figure 6 TX, RX Isolation

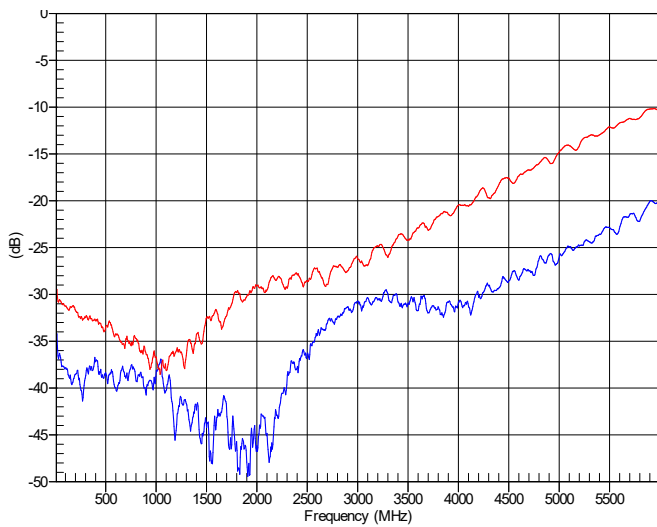

Figure 7 TX, RX Return Loss

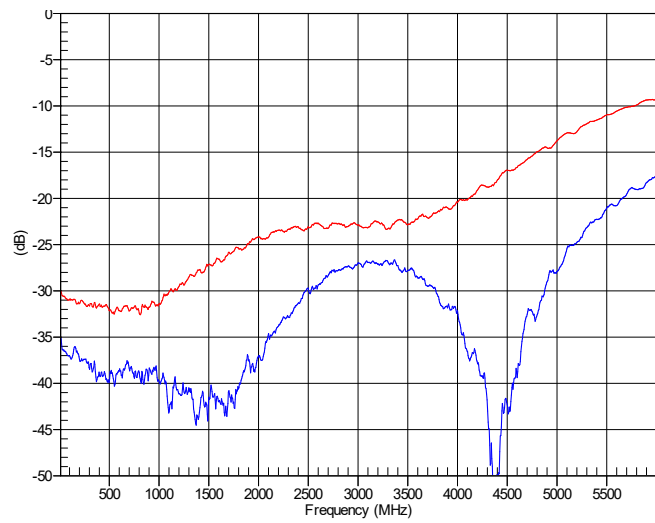

Figure 8 ANT Return Loss

10.2 With Match Tuned for 4.4~5GHz

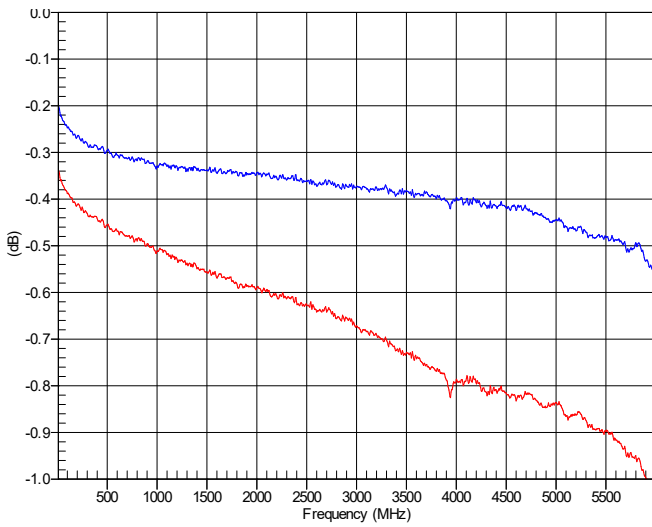

Figure 9 TX, RX Insertion Loss

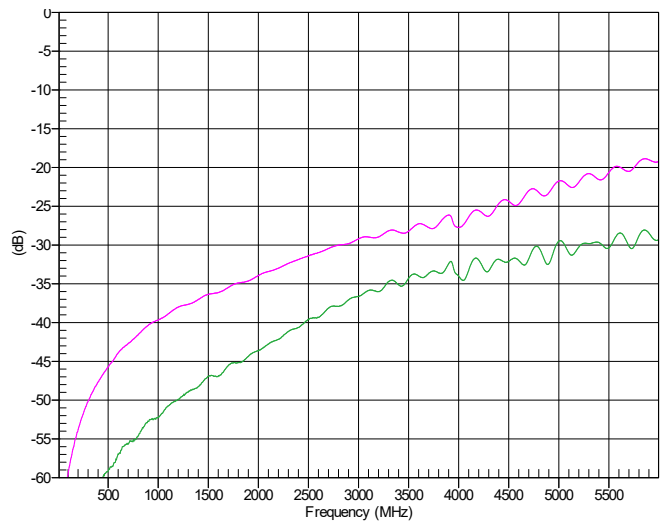

Figure 10 TX, RX Isolation

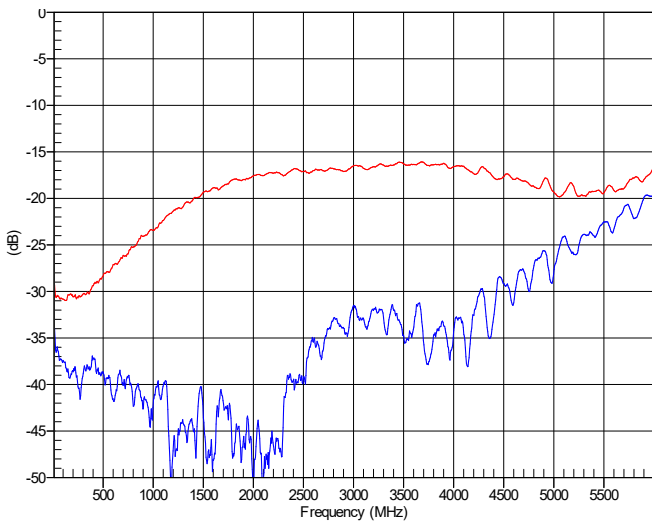

Figure 11 TX, RX Return Loss

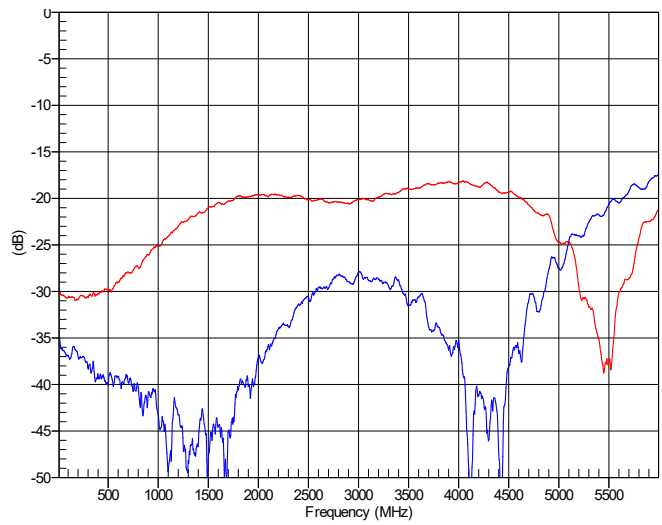

Figure 12 ANT Return Loss

11.0 Device Package Information

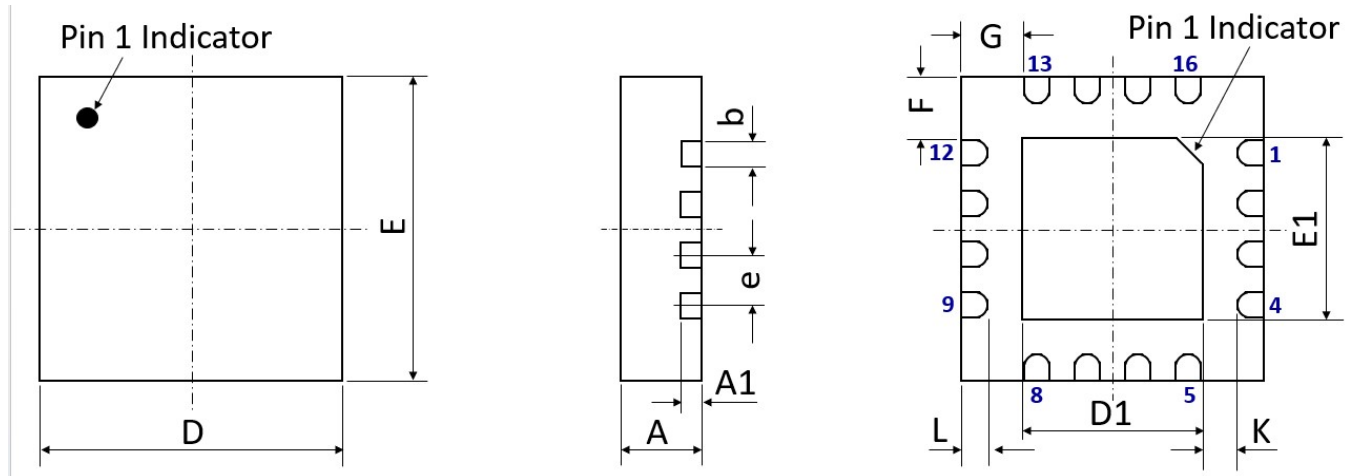

Figure 13 Device Package Drawing
(All dimensions are in mm)

Table 6 Device Package Dimensions

Dimension (mm)	Value (mm)	Tolerance (mm)	Dimension (mm)	Value (mm)	Tolerance (mm)
A	0.80	±0.05	E	3.00 BSC	±0.05
A1	0.203	±0.02	E1	1.70	±0.05
b	0.25	±0.05	F	0.625	±0.05
D	3.00 BSC	±0.05	G	0.625	±0.05
D1	1.70	±0.05	L	0.25	±0.05
e	0.50 BSC	±0.05	K	0.40	±0.05

Note: Lead finish: Pure Sn without underlayer; Thickness: 7.5µm ~ 20µm (Typical 10µm ~ 12µm)

Attention:

Please refer to application notes [TN-001](#) and [TN-002](#) at <http://www.tagoretech.com> for PCB and soldering-related guidelines.

Top-marking specification:

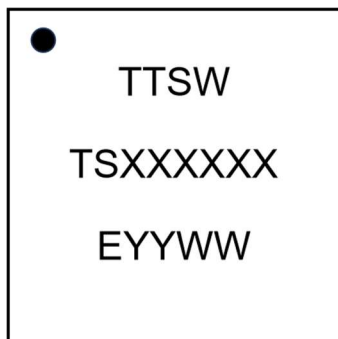

- = Pin 1 indicator
- TTSW = Tagore Technology SWitch
- TSXXXXXX = Part number (8 digits max)
- E = A fixed letter before the date code
- YY = Last two digits of assembly year
- WW = Assembly work week

12.0 PCB Land Design

Guidelines:

- [1] 4 layer PCB is recommended.
- [2] Via diameter is recommended to be 0.2mm to prevent solder wicking inside the vias.
- [3] Thermal vias shall only be placed on the center pad.
- [4] The maximum via number for the center pad is $3(X) \times 3(Y) = 9$.

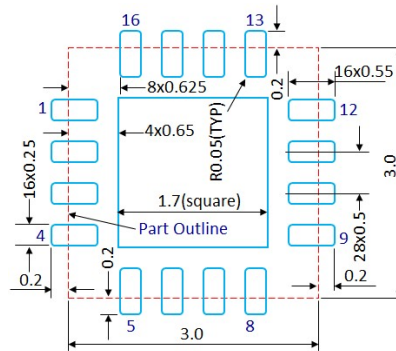

Figure 14 PCB Land Pattern
(Dimensions are in mm)

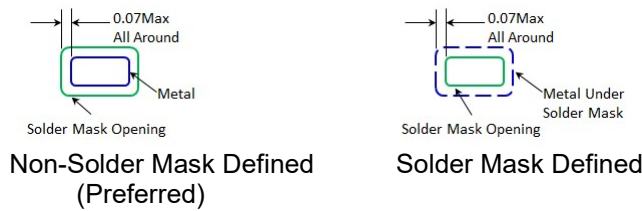

Figure 15 Solder Mask Pattern
(Dimensions are in mm)

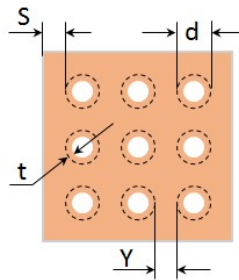

Figure 16 Thermal Via Pattern
(Recommended Values: $S \geq 0.15\text{mm}$; $Y \geq 0.20\text{mm}$; $d = 0.2\text{mm}$; Plating Thickness $t = 25\mu\text{m}$ or $50\mu\text{m}$)

13.0 PCB Stencil Design

Guidelines:

[1] Laser-cut, stainless steel stencil is recommended with electro-polished trapezoidal walls to improve the paste release.

[2] Stencil thickness is recommended to be 125µm.

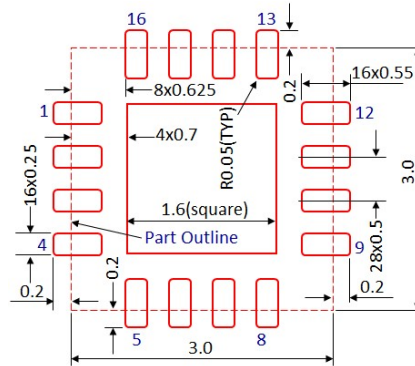

Figure 17 Stencil Openings
(Dimensions are in mm)

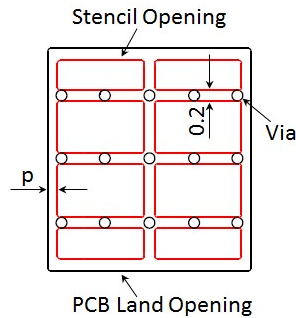

Figure 18 Stencil Openings Shall not Cover Via Areas If Possible
(Dimensions are in mm)

14.0 Tape and Reel Information

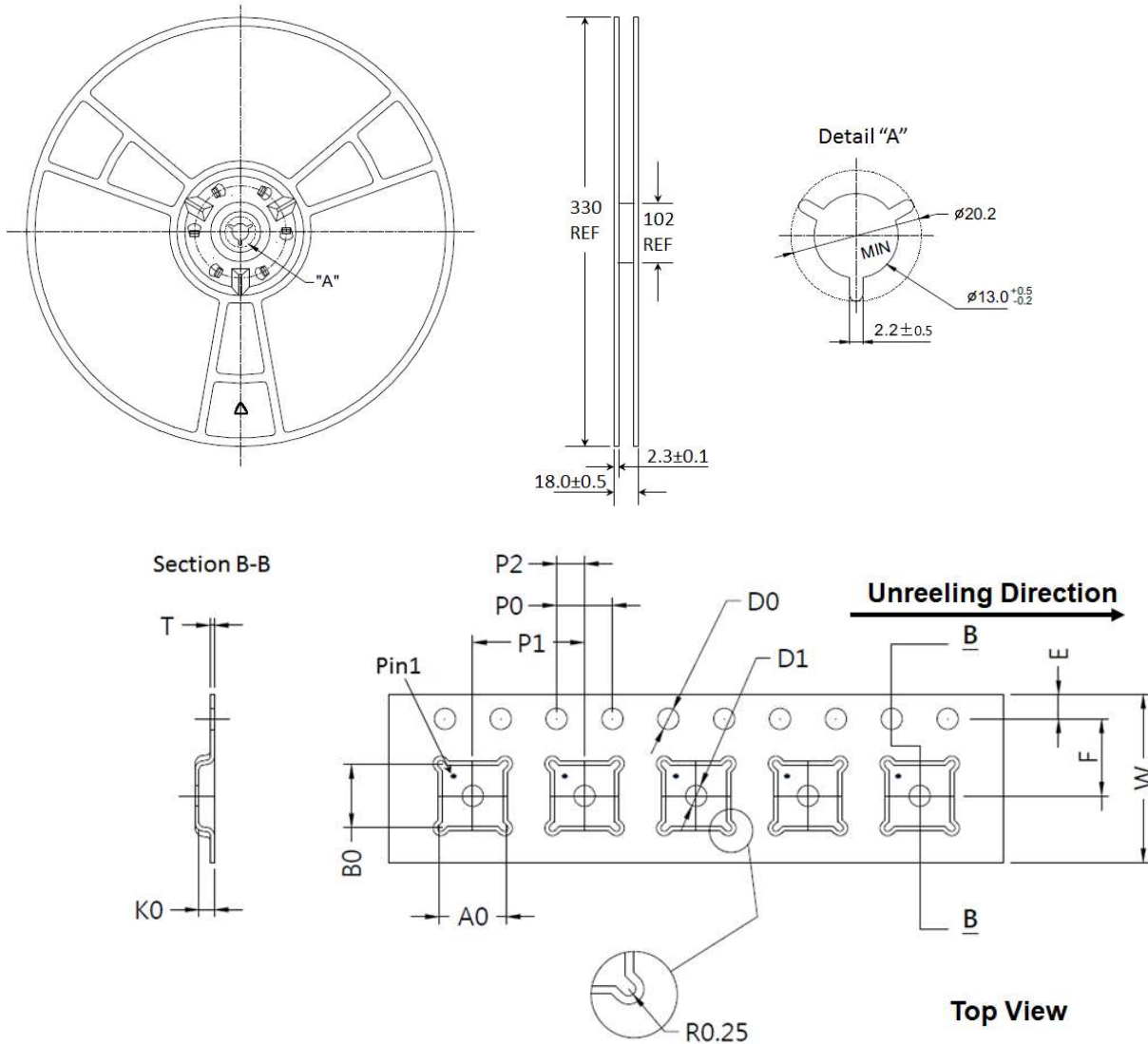

Figure 19 Tape and Reel Drawing

Table 7 Tape and Reel Dimensions

Dimension (mm)	Value (mm)	Tolerance (mm)	Dimension (mm)	Value (mm)	Tolerance (mm)
A0	3.35	±0.10	K0	1.10	±0.10
B0	3.35	±0.10	P0	4.00	±0.10
D0	1.50	+0.10/-0.00	P1	8.00	±0.10
D1	1.50	+0.10/-0.00	P2	2.00	±0.05
E	1.75	±0.10	T	0.30	±0.05
F	5.50	±0.05	W	12.00	±0.30

Edition Revision 2.4 - 2024-08-28

Published by

TagoreTech Inc.
601 Campus Drive, Suite C1
Arlington Heights, IL 60004, USA

©2018 All Rights Reserved

Legal Disclaimer

The information provided in this document shall in no event be regarded as a guarantee of conditions or characteristics. TagoreTech assumes no responsibility for the consequences of the use of this information, nor for any infringement of patents or of other rights of third parties which may result from the use of this information. No license is granted by implication or otherwise under any patent or patent rights of TagoreTech. The specifications mentioned in this document are subject to change without notice.

Information

For further information on technology, delivery terms and conditions and prices, please contact TagoreTech: support@tagoretech.com.